

Humidity / Temperature transmitter with large electroluminescent display
THA 300

- Ranges from 0-100%RH and -40 to +180°C (probe dependent)
- Configurable intermediate ranges
- Functions : relative and absolute humidity, dew point, wet and dry temperature, enthalpy.
- Smart-Pro interchangeable probes (PC or stainless steel)
- On-site calibration
- Simultaneous display of 1 to 4 parameters
- KIMO external transmitter inputs (Class 200 and 300)
- 2 analogue outputs 4-20 mA (4 wires) or 0-10 V, RS 232, 4 6A/230 Vac RCR relays (for Ref. CPA300)
- 2 6A/230 Vac RCR relays (for Ref. CPA300HV)
- Audible alarms (buzzer - 80 dB)
- Output diagnostics
- MODBUS network RS 485 system (optional)
- Multi-directional housing made of ABS V-0 as per UL 94
- Large display (50 x 190 mm)



THA 300 standard



THA 300 remote

Part number

To order, just add the codes to complete the part number.

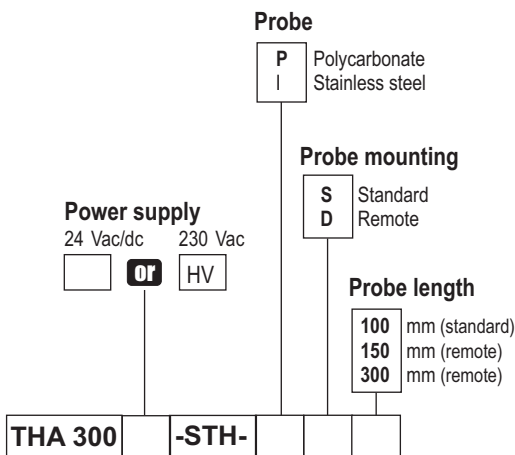

Example : THA 300 HV -STH- P S 100
Humidity and temperature transmitter with power supply 230 Vac. The probe is in polycarbonate, 100mm length and it is mounted in standard.

Transmitter features

Humidity

- Measuring range0 to 100 %RH
 Units of measurement%RH
 Accuracy* (Repeatability, linearity, hysteresis)±1,5%RH (from 3 to 98%RH and if 15°C≤T≤25°C)
 Temperature dependence±0.04 x IT-201%RH (if T<15°C or T>25°C)
 Response time<10 sec. (from 10%RH to 80%RH, V_{air}= 2 m/s)
 Resolution0,1 %RH
 Factory calibration uncertainty±0.88%RH
 Type of sensor.....capacitive
 Type of fluidair et neutral gases (high resistance to solvents)

Temperature

- Measuring rangefrom -20 to +120°C (Polycarbonate probe)
from -40 to +180°C (st.steel probe)
 Units of measurement°C, °F
 Accuracy *± 0,3% of reading ± 0,25°C
 Response timet_{0.9} = 9 sec. for V_{air} = 1 m/s
 Resolution0,1°C
 Type of sensor.....Pt 100 1/3 as per DIN IEC751
 Type of fluid.....air et neutral gases

**Analogue output is configured by default at our factory, from 0 to 50°C.

See « Configuration » part to configure analogue outputs.

* All accuracies indicated in this technical datasheet were stated in laboratory conditions, and can be guaranteed for measurements carried out in the same conditions, or carried out with calibration compensation. As per NFX 15-113 and the Charter 2000/2001 HYGROMETERS, GAL (Guaranteed Accuracy Limit) which has been calculated with a coverage factor value of 2 is ±2.58%RH between 18 and 28°C on the measuring range from 3 to 98%RH. Sensor drift is less than 1%RH/year.

Functions

THA 300 has 2 analogue outputs which corresponds to the 2 parameters displayed. You can activate 1 or 2 outputs and for each output, you can choose between humidity, temperature and the functions below :

Features Functions	Measuring range	Units and resolutions
Absolute humidity	from 2 to 900 g/Kg	0,1 g/kg
Dew point	from -80 to +180°C	0,1°C - 0,1°F
Humid temperature	from -20 to +180°C	0,1°C - 0,1°F
Enthalpy	from 0 to 15 000 Kj/Kg	0,1 Kj/Kg

THA 300 can display 4 parameters alternatively. The 2 last parameters are only dedicated to display and they have no output.

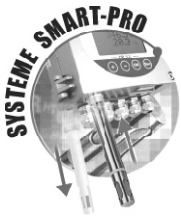

- Easy maintenance with the new SMART PRO digital probes.
- **Totally interchangeable** : they are individually adjusted and are automatically recognized by the transmitter.

Housing dimensions

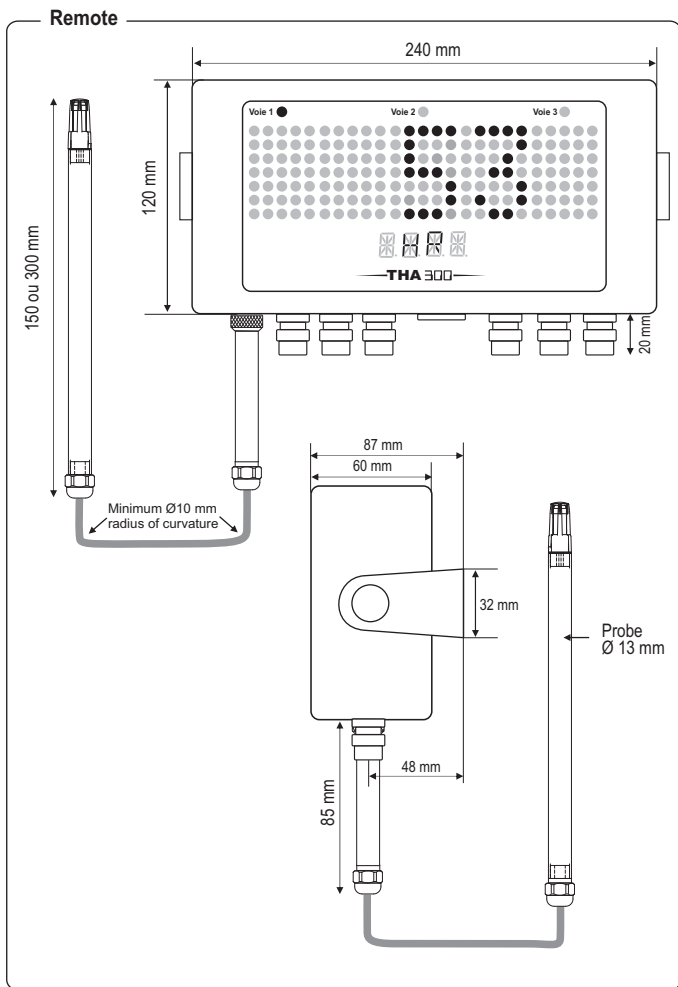
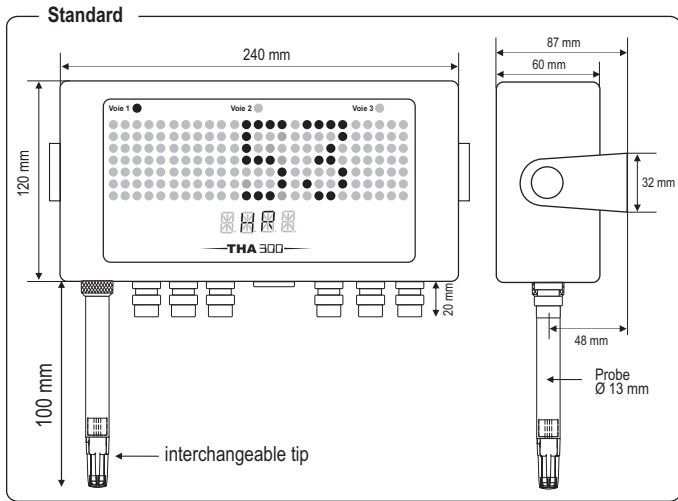

Housing features

- Housing** ABS, multi directional (30°)
- Protection** IP 63
- Fire-proof classification** V-0 as per UL 94
- Dimensions** see drawing
- Connection fitting** Polyamide for 7 mm max cable
- Weight** 1000 g

Probes features

White Polycarbonate probes

- Measuring range** -20 to +120°C
- Standard probe** Length 100 mm
- Remote probe** Length 150 or 300 mm (others on request)
- Cable** PVC Ø 4,8 mm, lg 2 m (others on request)

Polycarbonate probes are supplied with a flow-through polycarbonate protection tip with stainless steel filter 25 (ref.EPP2).

Stainless steel 316 L

- Measuring range** -40 to +180°C
- Standard probe** Length 100 mm
- Remote probe** Length 150 or 300 mm (others on request)
- Cable** silicone Ø 4,8 mm, lg 2 m (others on request)

Stainless steel probes are supplied with flow-through stainless protection tip with stainless steel filter 25 (ref.EPI25).

Tip selection

- Tip material** PC⁽¹⁾, St.Steel⁽²⁾ or PTFE⁽³⁾
- Filter material** St.Steel or PTFE
- Filter type** Meshed or sintered

(1) PC : White Polycarbonate - (2) St.Steel : 316 L - (3) PTFE : White Teflon®

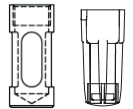

Display features

- Display** electroluminescent alphanumeric (75 x 190 mm)
protection screen made of inactive red PMMA
- 1st line (measurement)** ... 5 digits (dot matrix 5 x 7) 50 x 190 mm
- 2nd line (unit)** 4 digits (14 segments) 13 x 45 mm
- Number of channels** from 1 to 4 channels, alternatively (3 seconds)
- Location of channels** with 3 red identified LED
- Response time** < 1 sec.

Technical specifications

- Power supply** 24 Vac/Vdc ± 10%
230 Vac ± 10%, 50-60 Hz
- Output** 2 x 4-20 mA or 2 x 0-10 V (4 wires)
maximum load : 500 Ohms (4-20 mA)
minimum load : 1 K Ohms (0-10 V)
- Galvanic isolation** on the outputs
- Consumption** 5 VA
- Relays** for Ref. THA300 :
4 6A/230 Vac RCR relays
for Ref. THA300 HV :
2 6A/230 Vac RCR relays
- Audible alarms** buzzer (80 dB)
- Electro-magnetical compatibility** ... EN 61 326
- Electrical connection** screw terminal blocks for cables
Ø 1.5 mm² max
- RS485 communication** digital : RTU protocol Modbus
communication speed configurable
from 2400 to 115200 Bauds
- RS232 communication** digital : ASCII, proprietary protocol
- Working temperature** 0 to +50°C
- Storage temperature** -10 to +70°C
- Environment** air and neutral gases

Relays and Alarms

THA 300 has 4 stand-alone and configuration alarms :
4 RCR relays (contacts).

THA 300 HV has 2 stand-alone and configuration alarms :
2 RCR relays (contacts).

Settings available :

- selection of parameters (pressure, air velocity, temperature...)
- 1 or 2 setpoints (up & down) per alarm
- time-delay period from 0 to 60 sec
- action type : rising or falling action
- relay mode : negative or positive security
- audible alarm activation (buzzer)

Connection

- a. Analogue outputs
- b. Relays 1 and 2
- c. RS 485 connection
- d. Relays 3 and 4
- e. Power supply
- f. RS 232 connector
- g. Connection fittings
- h. Connector for Smart Pro hygrometry probe
- i. Output selection

THA 300 type

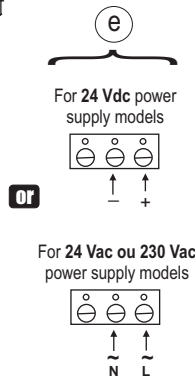
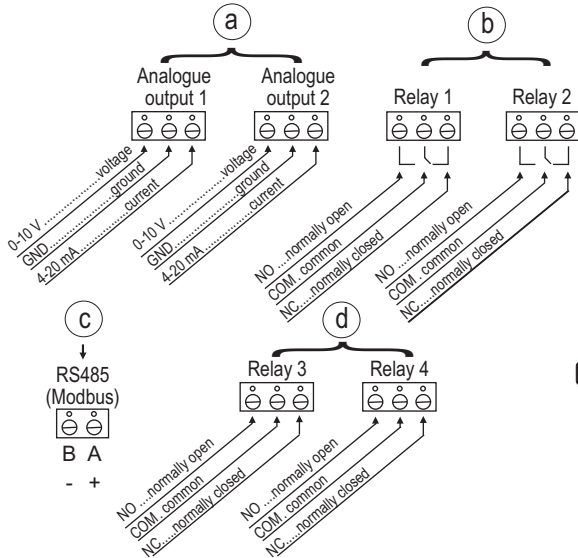
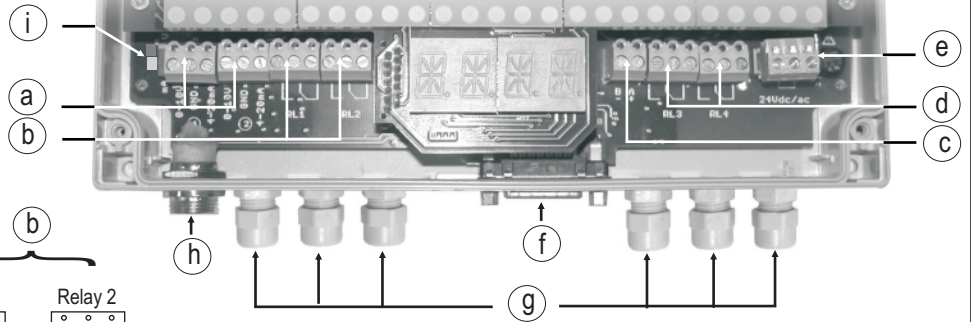

THA 300 HV type

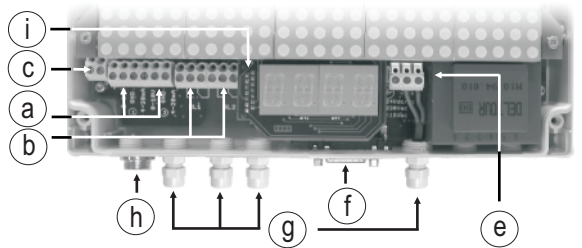

Electrical connections - as per NFC15-100 norm

⚠ This connection must be made by a qualified technician. Whilst making the connection, the transmitter must not be energized. Before making the connection, you must first check the power supply which is indicated on the transmitter board (see ① on the connection drawing)

Power supply connection :

- For 24 Vdc power supply models :

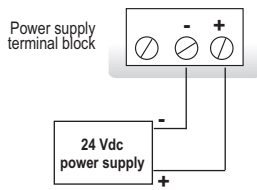

- For 24 Vac power supply models :

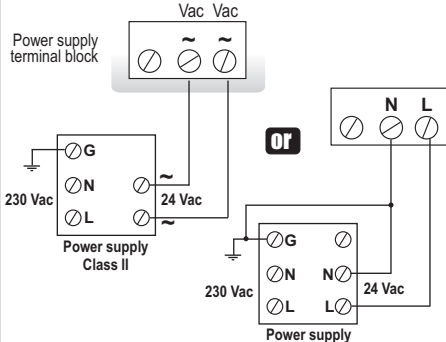

- For 230 Vac power supply models :

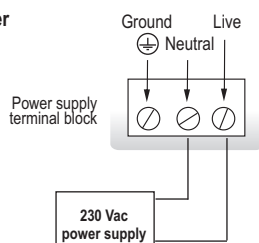

Output signal selection voltage (0-10 V) or current (4-20 mA)

The switch located on the left top of the transmitter (see ① on connection drawing) allows to select one of the 2 outputs.

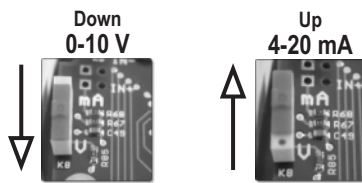

Output connection :

- 4-20 mA current output :

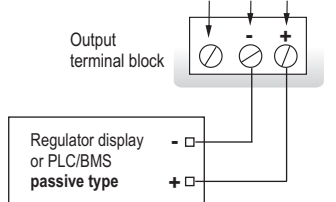

- 0-10 V voltage output :

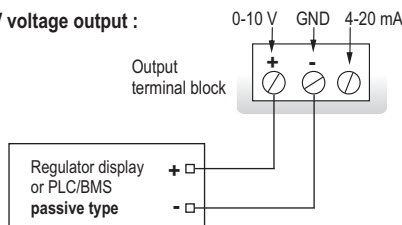

Connection of SUB-D15 RS 232 and RS 485

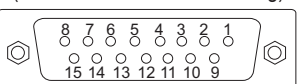

Pin #	Description
1	NC *
2	NC *
3	NC *
4	B - (RS 485)
5	A + (RS 485)
6	NC *
7	NC *
8	NC *
9	RX (RS 232)
10	NC *
11	TX (RS 232)
12	NC *
13	NC *
14	NC *
15	GND (RS 232)

⚠ CAUTION :
NC * --> DO NOT CONNECT

Digital communication

RS 232 communication



- Via RS 232 connection, THA 300 can display 1 or 2 parameters which are measured by other KIMO Class 200 and 300 transmitters.

Benefit : THA 300 can display (in addition to humidity and temperature) other parameters such as pressure, air velocity or airflow from a CP 200 for example.

- Via RS 232 connection, you can also configure your transmitter with the LCC-300 software.

- RS 232 connection cable is available in 2 m, 5 m or 10 m (max) lengths.

Modbus network (RS 485 system)

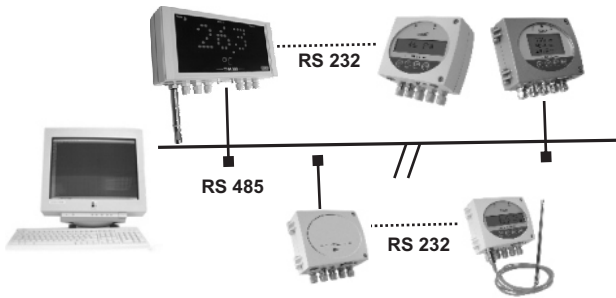

- Via THA 300, you can set up a network of transmitters/displays, on a RS 485 home bus (new or existing network).
- When a Class 200 or 300 transmitter is connected to THA 300 (via RS 232), all the measurements can be sent to the PLC/BMS via the RS 485, with only one address.
- RS 485 digital communication is a 2-wire network, on which the transmitters are connected in parallel. They are connected to a PLC/BMS via the RTU Modbus communication system. In the same way as THA 300 is configured with remote control, Modbus system enables to configure at distance : activate/deactivate a channel, set the measuring range of analogue outputs.

Configuration

You can configure all the parameters : units, measuring ranges, alarms, outputs, channels ... via the different methods shown below :

Via remote control (optional)

This is convenient in order to configure the transmitters located far from the user or hard to reach. Same way as with a keypad (see user manual).

Via software (optional)

Simple and user-friendly configuration. See LCC-300 user manual.

Via Modbus (optional)

Configuration of all parameters from your PC, via the supervision or data acquisition software.

Configurable analogue outputs

Configure the range according to your needs : outputs are automatically adjusted to the new measuring range.

Range with centre zero (-40/0/+40°C), with offset zero (-30/0/+70°C), or standard range (0 /+100°C) => you can configure your own intermediate ranges according to your needs, between 10% and 100% of the full scale.

The minimum configurable range is 10% of the full scale.

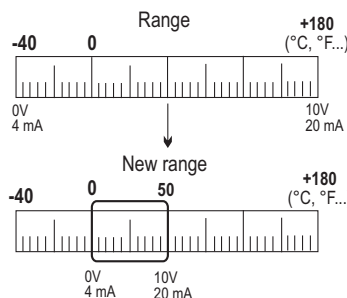

Calibration

On-site adjusting and calibration :

EHK 500 is a reference portable instrument which enables you to adjust at one point THA 300, by correcting any offset whilst measuring in a single ambient environment, housing both sensing elements. You can also adjust at several points.



Output diagnostics :

With this function, you can check with a multimeter (or a regulator/display, or a PLC/BMS) if the transmitter outputs work properly. The transmitter generates a voltage of 0 V, 5 V and 10 V or a current of 4 mA, 12 mA and 20 mA.



Certificate :

- Class 300 transmitters are supplied with adjusting certificates. Calibration certificate are offered as an option.
- Smart-Pro humidity probes are supplied with adjusting certificates and can also be supplied with calibration certificates offered as an option.

Mounting

With the 2 screws, install the mounting bracket in horizontal position along a plane wall (see below dimensions / drilling drawing).

Put the display inside the mounting bracket, with the 2 screws. Remove the screw covers located on the right and left side of housing, in order to have access to the 4 shutting screws.

Make the electrical connection with the connection glands, with soft cable Ø 7 mm maximum. Close the housing before powering on.

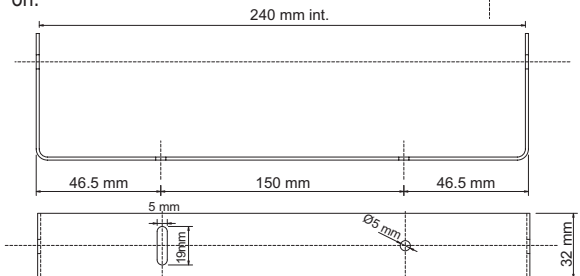
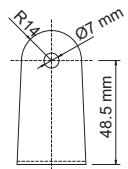

Maintenance

Avoid aggressive solvents.

Protect the transmitter and probes from any cleaning product containing formol, which may be used for cleaning rooms or ducts.

Options

- RS 485 digital output for Modbus protocol
- LCC 300 configuration software with RS 232 cable
- Infrared remote control for configuration
- Calibration certificate.



Optional accessories

- EHK 500 reference portable instrument
- Wall-mounting plate for humidity remote probe.
- Mounting brackets
- Sliding fittings
- Connection fittings
- Protection tips
- Caps for tips



www.kimo.fr

Distributed by :



EXPORT DEPARTMENT

Tel : + 33. 1. 60. 06. 69. 25 - Fax : + 33. 1. 60. 06. 69. 29

e-mail : export@kimo.fr