

Ammonia and Nitrogen Oxides Analyzer Model AC32M-CN_{H3}

Ambient Air
Quality Monitoring



4 selectable modes:

- Continuous NH₃
- Continuous NO / NO₂ / NH₃
- Continuous NO / NO₂
- Continuous NO

Applications:

- Low level ammonia monitoring in ambient air
- Odour continuous monitoring (wastewater plants, chemical industries)
- Workplace monitoring

Exclusive features:

- Type approvals: TÜV report n° 936/21205818/C (Germany), US EPA n°RFNA-0202-146 (USA) for AC32M
- Chemiluminescence principle with NH₃ → NO converter
- Graphic Liquid Crystal Display (LCD)
- Interactive menu driven software with enhanced speed display
- Real-time synoptic flow diagram display
- User programmable ranges and average time
- Auto-ranging
- Automatic and programmable response time
- Real time calibration graph
- Built-in storage of 1 months 1/4 h average data (up to 6 months with the optional memory extension)
- Built-in double serial interface (RS 232/RS 422) for remote control

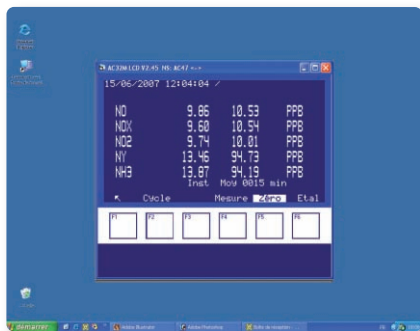

CONTACT™ remote maintenance software

Ammonia and Nitrogen Oxides Analyzer

Specifications:

- Ranges: 0 - 0.10 / 0.25 / 0.50 / 1 ppm
- Lower detectable limit: 0.001 ppm
- Span drift: < 1% / week (with zero cycle on)
- Response time: 180 seconds
- Span drift: < 1% / week
- Linearity: +/- 1% of full scale
- NH₃ / NO converter : Quartz, 980 °C
- Dim. AC32M : 545 x 483 x 133 mm (W x D x H)
- Dim. CNH3 : 545 x 483 x 133 mm (W x D x H)
- Weight AC32M: approx. 13 kg
- Weight CNH3: approx. 8 kg
- Operating temperature: +10 °C to +35 °C
- Serial communication: 2 x RS 232 or 422

Utilities:

- Power supply: 230 V, 50 Hz or 115 V, 60 Hz
- Consumption
 - CNH3 : 160VA
 - AC32M : 250 VA

Options:

- Internal permeation bench (AC32M module)
- ESTEL board (1 or 2 boards) each including :
 - 4 independent analog inputs
 - 4 independent analog outputs
 - 4 eremote control inputs
 - 6 dry contacts

Operating principle:

Model AC32M-CN_{H3} consists of 2 associated modules:

- a NH₃ → NO converter (ref CNH3-S2)
- a NO_x analyzer (ref AC32M)

The gas sampled by the terminal pump crosses the filter-solenoid valve block.

The sample is then divided into two parts: one part goes through the CNH3 module, and the other one goes directly to the standard AC32M circuitry. The EVNH3 solenoid valve is used to take the sample either directly from the EV filter block, or from the CNH3 module.

In order to minimize the analyer response time, a pump is placed in the CNH3 module. In association with a restrictor and an exhaust located in the AC32M, this pump allows a fast refreshment of the sample gas to be analyzed.

The sample flows, on the one hand, through the NH₃ rack where NH₃ is oxidized into NO, and, on the other hand, through the molybdenum converter oven where the NO₂ is reduced into NO.

The sample finally reaches the reaction chamber, where quantities of NO_x (NO + NO₂) and NO_y (NO + NO₂ + NH₃) are measured using the chemiluminescence principle. The value NO_y - NO_x represents the concentration of NH₃ present in the sample.

For more specific information on model AC32M, please consult the AC32M brochure.

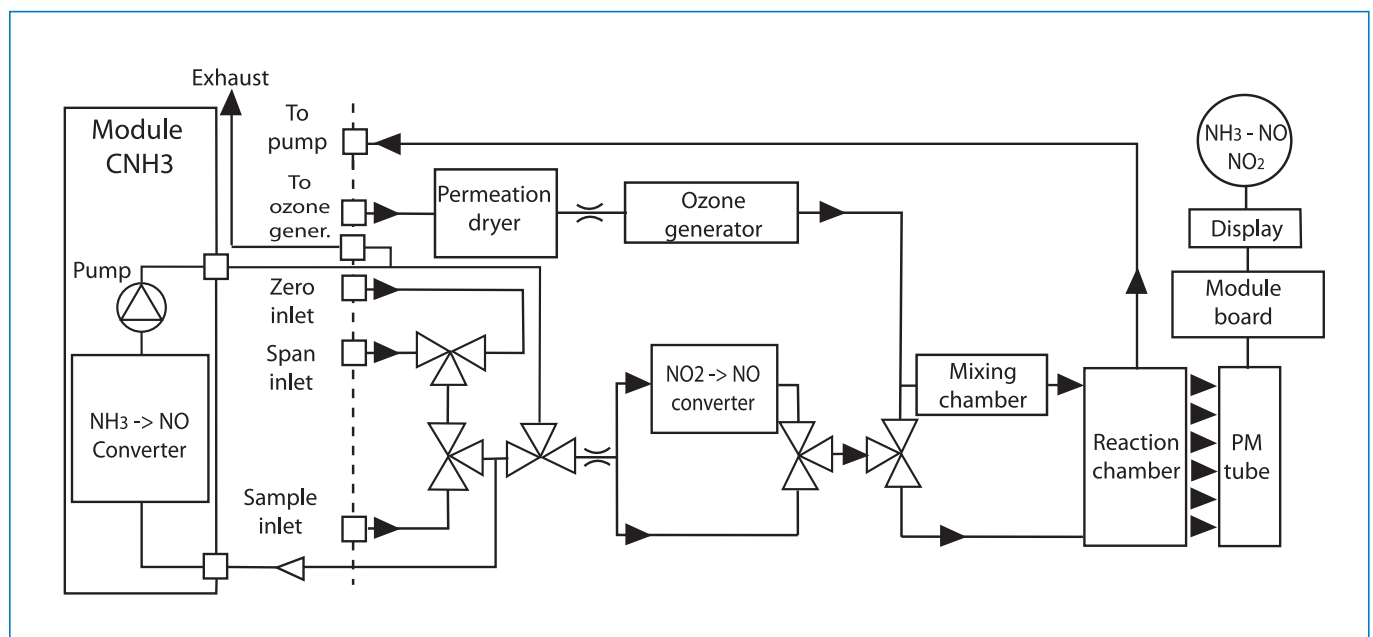

Specifications subject to modifications without prior notice - ref.: T1100-AC32M-NH3_uk - Gimmick