

Gas Chromatograph Volatil Organic Compounds Analyzer (PID or FID) Model VOC71M

Ambient Air
Quality Monitoring

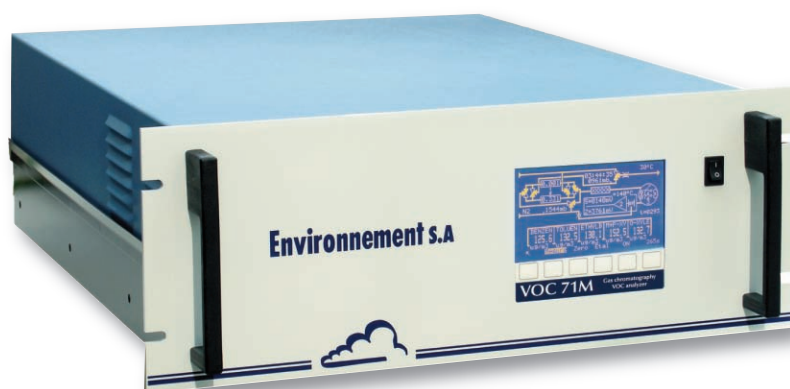

Complies with
EN 14662:2005
standard

BTEX measurement:

- Benzene,
- Toluene,
- Ethyl-benzene,
- m & p-Xylene,
- o-Xylene
- 1-3 Butadiene (option)

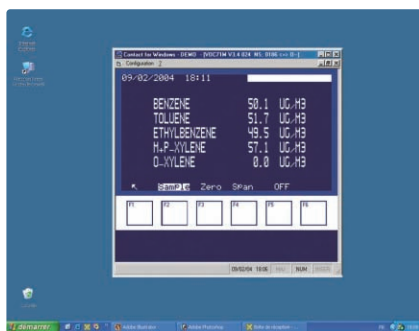

CONTACT remote control software

Major fields of application:

- Ambient air monitoring
- Monitoring of industrial sources emitting VOCs
- Photochemical pollution studies (stationary and mobile laboratories)

Exclusive features:

- Evaluated by AEA (United Kingdom)
- High sensitivity, stable, linear PID or FID detector
- Long-life capillary column
- Selectable 15 or 30 minute cycles for continuous sampling
- Self-contained and completely automated
- Nitrogen (PID) or hydrogen (FID) used as carrier gas
- Graphic Liquid Crystal Display (LCD)
- Interactive menu driven software
- Synoptic flow diagram display
- Remote troubleshooting diagnostics
- RS232 or RS422 interface and 8 analog outputs
- Stand alone analyzer (PC not required)

Gas Chromatograph VOC Analyzer (PID or FID) - model VOC71M

Specifications:

- Measured compounds: Benzene, Toluene, Ethyl-benzene, m,p-Xylene and o-Xylene
- Measurement ranges:
0-100, 0-200, 0-1,000 $\mu\text{g}/\text{m}^3$
- Measurement cycle:
15 or 30 minutes (selectable)
- Lower detectable limits:
- 0.5 $\mu\text{g}/\text{m}^3$ for the 15-min cycle (benzene)
- 0.3 $\mu\text{g}/\text{m}^3$ for the 30-min cycle (benzene)
- FID or PID detector (to be chosen)
- Sample volume:
- 1 l for the 15-minute cycle
- 2 l for the 30-minute cycle
- Desorption tube: Carbotrap®
- Preconcentration: Carbopack®
- Column: EPA type 624, 10 m, thermo-regulated
- Sample flow rate: 0.07 l/min.
- 8 selectable analog outputs (one for each measured compound):
0-1 V, 0-10 V, 0-20 mA, 4-20 mA
- Data storage: last 1,500 average value for each compound
- Serial link: 2x RS232 or RS422
- Dimensions: (W x D x H):
483 mm x 600 mm x 177 mm
- Weight: 22 kg
- Power supply:
230 V / 50 Hz or 115 V / 60 Hz
- Power consumption: 360 VA maximum
- Operating temperature: +10 to +35 °C

Utilities:

- PID version : Nitrogen N55
40 ml/min, 2 bars
- FID version : Hydrogen
30 ml/min, 2 bars

Options:

- Other columns upon request
- 1-3 Butadiene measurement
- Internal permeation bench
- Winchrom® software:
- Multi-task data management software for Windows 9x/2000/XP
- Real time chromatograms display and data storage
- Export data in Ascii and xls formats for processing tasks such as calculation of specific parameters

Operating principle:

The metrology of Model VOC71M is based on the gas chromatographic separation of the compounds of interest combined with a detection achieved by a photo ionization detector (PID) or a flame ionization detector (FID).

The VOC71M combines three main functions : Sampling / Analysis / Data Handling. The sampling is performed in cyclic mode with two tubes filled with selective sorbents. While one tube is collecting sample, the other one is desorbed. This allows the instrument to achieve nearly 100 % sampling time coverage.

The analysis is performed, first through a pre-concentration tube interfacing the sampling tubes and the chromatographic column, thus eliminating interferences.

The desorbed sample is then injected into a fused silica capillary column for separation. A controlled temperature gradient oven permits a fast and accurate separation of VOC. Compounds are identified by their elution times through the capillary column.

The VOC71M is controlled by an internal microprocessor board, which handles the automated sampling, user interface, data management and storage.

The VOC71M is a unique, rack mounted, stand-alone, fully automated instrument for monitoring low level specific volatile organic compounds such as benzene, toluene, ethylbenzene and xylenes. It is particularly well adapted for applications in air quality monitoring (urban and industrial sites). It is compact and yet allows performances comparable to laboratory gas chromatography instruments.

Multi-task software combined with the LCD graphic display, give the user easy and fast access to the instrument setup, status and maintenance parameters. Real-time synoptic, auto-diagnostic and maintenance data screens can be displayed while the instrument is operating.

The built-in RS232/RS422 interface and digital communication protocol allow full PC instrument emulation for remote control and troubleshooting as well as a serial link.

The VOC71M may be operated either as a stand-alone instrument or linked to a PC, with a Windows™ based software WinCHROM, for hard disk storage of chromatograms, and post-data processing. The VOC71M, is probably the most compact, versatile and cost-effective VOC analyzer available for ambient air monitoring networks.

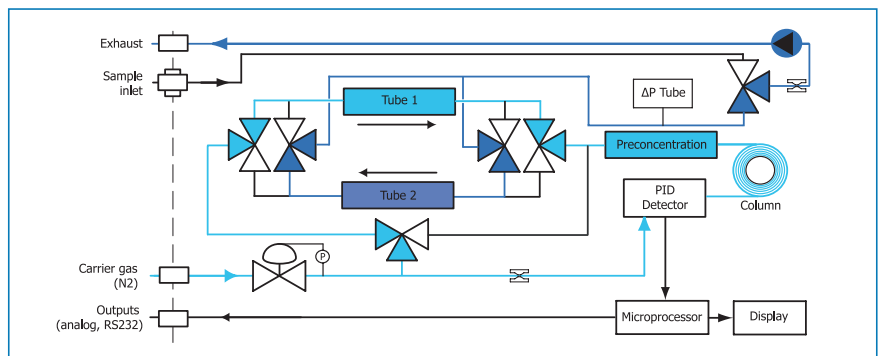

Specifications subject to change without prior notice - ref.: 1108 - VOC71M_uk - Gimmick